

*z/VM and IBM System z ... your path to success*



## **Table of Contents**

<i>What is z/VM?</i>	<i>page 3</i>
<i>CMS Interactive Support</i>	<i>page 11</i>
<i>VM Server Support</i>	<i>page 11</i>
<i>Guest Operating System Support</i>	<i>page 13</i>
<i>Performance</i>	<i>page 15</i>
<i>Connectivity Options</i>	<i>page 16</i>
<i>Communication Products</i>	<i>page 16</i>
<i>z/VM Decision Support</i>	<i>page 18</i>
<i>Open Computing</i>	<i>page 19</i>
<i>z/VM System Management Products</i>	<i>page 19</i>
<i>Configurability</i>	<i>page 21</i>
<i>VM Evolution</i>	<i>page 22</i>
<i>VM Operating System Comparison</i>	<i>page 23</i>
<i>VM Feature Comparison</i>	<i>page 24</i>
<i>To Learn More</i>	<i>page 25</i>

## What is z/VM?

The z/VM® hypervisor offers a base for customers who want to exploit IBM® virtualization technology on one of the industry's best-of-breed server environments, the IBM System z™ family, including the new IBM System z10 Enterprise Class. The z10 EC is designed to reduce energy usage and save floor space. With increased capacity and the number of available processor units per server, the z10 EC virtualization capabilities can support more virtual servers than any of its competitors – thousands of virtual servers in a single footprint. When consolidating onto System z you can create virtual servers on demand, achieve network savings through HiperSockets™ (internal LAN), improve systems management of virtual servers and most importantly save on software. With System z virtualization, customers can easily create many virtual machines consisting of virtualized processors, communications, memory, networking, and I/O resources. Virtualization technology may help lower your total cost of ownership when deploying new enterprise application workloads. z/VM includes nearly 40 years of innovation and invention.

### **z/VM Version 5 Release 3 – Enhancements in scalability, security, and virtualization technology**

- Scalability and constraint relief enhancements
  - Support for larger Logical Partitions (LPARs) up to 256 GB of real storage (memory) and more than 1 TB<sup>1</sup> of total virtual memory in use by guests
  - Up to real 32 processors in a single z/VM image
  - Improved memory management algorithms to help benefit paging workloads with large memory environments with the PTF for APAR VM64349

*Note:*<sup>1</sup> The actual amount of usable real and virtual memory is dependent on the amount of real memory in the z/VM logical partition, the hardware server model, firmware level, and configuration, and the number of guests and their workload characteristics.

- Support for the Collaborative Memory Management Assist (CMMA) by which host and guest exchange information to optimize their use and management of memory (Refer to the z/VM V5.3 Performance Report for CMMA usage.)
- Enhanced memory utilization using Virtual Machine Resource Manager (VMRM) between z/VM and Linux® guests
- Support for the Hyper Parallel Access Volume (HyperPAV) function of IBM System Storage™ DS8000™ series
- Enhanced FlashCopy support allows:
  - Specification of up to 12 target minidisks
  - Determination of the status of FlashCopy requests
  - Exploitation of hardware asynchronous cache destage and discard
- Support for the IBM System Storage SVC Storage Engine 2145 allows Linux on System z guests of z/VM V5 (all releases) to access IBM System Storage disk subsystems, including the DS4000™ series, and OEM SCSI disk devices supported by the SVC
- Virtualization technology and Linux enablement
  - New guest support for specialty processors, the IBM System z™ Application Assist Processors (zAAPs) and System z9® Integrated Information Processors and System z10® Integrated Information Processors (zIIPs) including:
    - Simulation support - z/VM guest virtual machines can create virtual specialty processors on processor models that support the same types of specialty processors but don't necessarily have them installed. Virtual specialty processors are dispatched on real Central Processors (CPs), allowing users to assess the operational and CPU-utilization implications of configuring a z/OS® system with zIIP or zAAP processors without requiring the real specialty processor hardware.

- Virtualization support - z/VM can create virtual specialty processors for virtual machines by dispatching the virtual specialty processors on corresponding real specialty processors of the same type, which may help improve your total cost of ownership by allowing available zAAP and zIIP capacity not being used by z/OS LPARs to be allocated to a z/VM LPAR hosting z/OS guests running Java™ and DB2® workloads
- IBM intends to further enhance z/VM in a future release to exploit the new System z10 EC support for a new logical partition (LPAR) mode “VM”, exclusively for running z/VM LPARs. This new LPAR mode allows z/VM to utilize a wider variety of specialty processors in a single LPAR. For instance, in a VM mode LPAR, z/VM can manage Linux on System z guests running on IFL processors while also managing z/OS guests running on central processors (CPs) and zIIPs and zAAPs
- Usability enhancements for the virtual switch (VSWITCH) and guest LAN environments including enhanced ease-of-use for Virtual LAN (VLAN) and promiscuous mode configuration changes
- Guest use of Modified Indirect Data Address Words (MIDAWs) to allow more flexibility and performance in certain channel programs as an alternative to data-chained channel-command words (CCWs)
- Guest access to the system ASCII console to facilitate recovery of the guest during an emergency
- Additional enhancements to Small Computer System Interface (SCSI) disk support for Linux users
- Secure Sockets Layer (SSL) server support for additional Linux distributions
- Technology exploitation
  - Guest exploitation of the System z10 EC at the level of System z9 functionality with the PTFs for APARs VM64180 and VM64242
  - Exploitation of selected functions of the System z10 EC including:
    - Dynamic I/O configuration to define, modify, and query a Coupling using InfiniBand® link, CHPID type CIB, when z/VM V5.3 is the controlling LPAR for dynamic I/O
    - Processors dynamically added to or removed from a z/VM LPAR in reserve without preplanning with the PTFs for APARs VM64249, VM64323, and VM64389
    - TCP/IP and VSWITCH gaining the performance benefit of OSA-Express3 10 GbE on the z10 EC
    - Additional PTFs must be applied to support the z10 EC:
      - EREP support requires the PTF for APAR VM64367
      - CMS IOCP support requires the PTF for APAR VM64302
      - HCD support requires the PTF for APAR VM64020
  - Support for Dynamic Volume Expansion simplifying disk management by allowing for the dynamic increase of a DS8000 volume size in order to accommodate application data growth with the PTFs for APARs VM64305 and VM64354
- Network virtualization
  - Enhanced ease-of-use for virtual networks
  - Enhanced failover support for IPv4 and IPv6 devices
  - Virtual IP Address (VIPA) support for IPv6
  - VSWITCH support for OSA-Express2 and OSA-Express3 link aggregation for increased throughput and provides more seamless nondisruptive failover in the event that an OSA port in the group becomes unavailable

- *New port isolation security mechanism provides the ability to restrict guest-to-guest communications within a VSWITCH with the PTF for APAR VM64281*
  - *Security enhancements*
    - *New LDAP server and associated client utilities*
    - *Enhanced system security with support for longer passwords (password phrases)*
    - *z/VM SSL server enhancements designed to help improve security*
    - *Tape data protection with support for encryption*
      - *Encryption Re-Key support provides the capability to update a previously encrypted tape cartridge with a new set of Key Encryption information to help allow for a continuous protection of tape cartridge data with the PTF for APAR VM64260*
  - *Systems management enhancements*
    - *Enhanced Systems Management API with sockets-based server and new functions to manage virtual machines*
    - *z/VM systems management functions to be performed from the HMC to manage guests without having to establish additional network connections and reducing complex configuration of the system*
      - *IBM intends to further enhance z/VM in a future release to exploit the new Hardware Management Console (HMC) interface that allows the installation of Linux on System z into a z/VM virtual machine. Additionally, future support is planned for z/VM and the HMC to provide z/VM hypervisor-configuration tasks.*
    - *New function level for Directory Maintenance Facility (DirMaint™)*
    - *Enhancements to the Performance Toolkit for VM™*
      - *Correct display of the z10 EC and z9 processor models with the PTF for APAR VM64369*
  - *Enhanced guest configuration with a new COMMAND statement*
  - *Installation, service, and packaging changes*
    - *Additional DVD installation options*
    - *RSCS repackaged as a priced, optional IPLA feature that can be licensed for IFL and standard processors*
    - *New RACF® Security Server for z/VM*
- z/VM Version 5 Release 2 – Enhancements for Virtualization on System z**
- *Virtualization technology and Linux enablement:*
    - *Enhanced exploitation of real memory beyond 2 GB*
    - *Improved memory management algorithms to help benefit paging workloads with large memory environments with the PTF for APAR VM64349*
    - *Enhanced performance of z/VM Control Program (CP) use of SCSI disk I/O*
      - *QDIO efficiency enhancements*
      - *Paging and spooling optimization*
    - *Enhanced FBA emulation, helping to reduce the number of I/O requests to the VM SCSI stack with:*
      - *CP's FBA emulation functions reading CMS I/O buffers more efficiently*
      - *More efficient FBA emulation handling Locate CCWs more efficiently*
      - *More efficient FBA emulation handling the FBA padding function more efficiently*
    - *Definition and operation of Fibre Channel Protocol (FCP)-attached SCSI disks with capacities of approximately 1 TB with the PTFs for APAR VM63700 (DirMaint) and VM63664 (DFSMS/VM™)*

- SSL server support for additional Linux distributions
- Enhanced performance assist for cooperating z/VM guests using OSA-Express, FCP, and HiperSockets™
- Enhanced systems management APIs for enhanced management of Linux and other guests
- Network virtualization and security:
  - Improved problem determination for guest LANs and virtual switches
  - Enhanced dynamic routing capabilities with new MPPRoute server
  - New port isolation security mechanism provides the ability to restrict guest-to-guest communications within a VSWITCH with the PTF for APAR VM64281
- Technology exploitation:
  - Guest exploitation of the System z10 EC at the level of System z9 functionality with the PTFs for APARs VM64180 and VM64242
  - Additional PTFs must be applied to support the z10 EC:
    - EREP support requires the PTF for APAR VM64367
    - CMS IOCP support requires the PTF for APAR VM64302
    - HCD support requires the PTF for APAR VM64020
  - Exploitation of selected functions of the System z10 EC including:
    - TCP/IP and VSWITCH gaining the performance benefit of OSA-Express3 10 GbE on the z10 EC
  - Exploitation of selected features of the IBM System z9 Enterprise Class (z9 EC) and the System z9 Business Class (z9 BC):
    - Support for new instructions<sup>1</sup>
    - Support for FICON® Express4 (4 Gbps FICON)
    - TCP/IP and guest LAN Support for HiperSockets using IPv6 protocol<sup>1</sup>
    - Simplified VLAN management with support for Generic Attribute Registration Protocol (GARP) Virtual Local Area Network (VLAN) Registration Protocol (GVRP)<sup>1</sup>
    - Crypto Express2 Accelerator for SSL acceleration
    - Support for OSA-Express2 OSN (OSA for NCP)
    - Enhanced FCP channel utilization and sharing among guests through N-Port ID virtualization (NPIV) support
    - Support for hardware capability to add and delete logical partition (LPAR) names
    - Support for hardware capability to provide up to 60 LPARs on the z10 EC, z9 EC and 30 on the z9 BC
    - Additional exploitation of IBM System Storage DS6000™ and IBM System Storage DS8000 series with the PTF for APAR VM63952
    - Support for Dynamic Volume Expansion simplifying disk management by allowing for the dynamic increase of a DS8000 volume size in order to accommodate application data growth with the PTFs for APARs VM64305 and VM64354
    - Support for Parallel Access Volumes (PAVs) as minidisks with the PTF for APAR VM63952
- Systems management:
  - Simplified user administration with the coordination of DirMaint and RACF changes
  - Enhanced DirMaint directory management performance
  - Performance Toolkit for VM to support updated control

blocks, new monitor data, and enhanced ease-of-use'

- Correct display of the z10 EC and z9 processor models with the PTF for APAR VM64369

- To support the z9 EC and z9 BC on V5.2, the PTFs for the following APARs are required

- VM63946 - EREP
- VM63921 - CMS IOCP
- VM63952 - CP, CMS IOCP, TCP/IP, DirMaint, Performance Toolkit, HCD/HCM, and OSA/SF

(See z/VM Version 5.2 General Information – GC24-6095)

### **A solution that builds on z/VM hypervisor strengths**

- Virtualization technology
- Guest operating system support
- Extensive connectivity options
- Linux server consolidation platform
- CMS interactive support
- Server support
- Client/server workstation synergy
- Open distributed computing
- Ideal Web serving platform
- Wide range of environments and applications

For a complete list of publications available, refer to the z/VM Web site at:

---

[ibm.com/zseries/zvm/library/](http://ibm.com/zseries/zvm/library/)

---

### **z/VM supports a wide range of industry standards**

- Networking protocols and connections, languages, programming and graphical user interfaces (GUI)

- POSIX support
- FICON and SCSI support

### **z/VM manages the enterprise**

- Dynamic system configuration capabilities help reduce planned and unplanned outages
- DFSMS/VM provides automated data management for Shared File System (SFS), POSIX Byte File System (BFS) files, and minidisk restructuring
  - Provides interfaces for Tivoli Storage Manager™ (TSM) tape library usage
  - Allows VSE/ESA™ or z/VSE™ guest access to automated tape libraries containing 3480, 3490, 3590, and 3592 devices
  - Support for approximately 1 TB SCSI disks with the PTF for APAR VM63664
  - Multi-user tape support with the PTF for APAR VM63746
  - Tape encryption support for z/VSE guest with the PTF for APAR VM64062

### **z/VM embraces the latest technology**

#### **z/VM Version 5 Release 3 provides:**

- Support for larger LPARs up to 256 GB of real memory and more than 1 TB of total virtual memory in use by guests
- Support for up to 32 real processors in a single z/VM image
- Improved memory management algorithms to help benefit paging workloads with large memory environments with the PTF for APAR VM64349

- Support for the Collaborative Memory Management Assist (CMMA), by which by host and guest exchange information to optimize their use and management of memory (Refer to the z/VM V5.3 Performance Report for CMMA usage.)
- Guest exploitation of the System z10 EC at the level of System z9 functionality with the PTFs for APARs VM64180 and VM64242
- Exploitation of selected functions of the System z10 EC including:
  - Processors dynamically added to or removed from a z/VM LPAR in reserve without preplanning with the PTFs for APARs VM64249, VM64323, and VM64389
  - TCP/IP and VSWITCH gaining the performance benefit of OSA-Express3 10 GbE on the z10 EC
- Support for the HyperPAV function of IBM System Storage DS8000 series
- Support for Dynamic Volume Expansion simplifying disk management by allowing for the dynamic increase of a DS8000 volume size in order to accommodate application data growth with the PTFs for APARs VM64305 and VM64354
- Enhanced FlashCopy support that allows:
  - Specification of up to 12 target minidisks
  - Determination of the status of FlashCopy requests
  - Exploit hardware asynchronous cache destage and discard
- Support for the IBM System Storage SVC Storage Engine 2145
- New guest support for specialty processors, the System z zAAPs and System z9/System z10 zIIPs:
  - Simulation support - z/VM guest virtual machines can create virtual specialty processors on processor models that support the same types of specialty processors but do not necessarily have them installed. Virtual specialty processors are dispatched on real Central Processors (CPs), allowing users to assess the operational and CPU-utilization implications of configuring a z/OS system with zIIP or zAAP processors without requiring the real specialty processor hardware.
- Virtualization support - z/VM can create virtual specialty processors for virtual machines by dispatching the virtual processors on corresponding real specialty processors of the same type, which may help improve your total cost of ownership by allowing available zAAP and zIIP capacity that is not being used by z/OS LPARs to be allocated to a z/VM LPAR hosting z/OS guests running Java and DB2 workloads
  - IBM intends to further enhance z/VM in a future release to exploit the new System z10 EC support for a new logical partition (LPAR) mode “VM”, exclusively for running z/VM LPARs. This new LPAR mode allows z/VM to utilize a wider variety of specialty processors in a single LPAR. For instance, in a VM mode LPAR, z/VM can manage Linux on System z guests running on IFL processors while also managing z/OS guests running on central processors (CPs) and zIIPs and zAAPs
- Guest use of MIDAWs
- z/VM systems management functions to be performed from the HMC to manage guests without having to establish additional network connections and reducing complex configuration of the system.
  - IBM intends to further enhance z/VM in a future release to exploit the new Hardware Management Console (HMC) interface that allows the installation



of Linux on System z into a z/VM virtual machine.

– Additionally, future support is planned for z/VM and the HMC to provide z/VM hypervisor-configuration tasks.

- Guest access to the system ASCII console to facilitate recovery of the guest during an emergency
- Guest access to the system ASCII console to facilitate recovery of the guest during an emergency
- Additional enhancements of SCSI disk support for Linux users
- VSWITCH support for OSA-Express2 and OSA-Express3 link aggregation for increased throughput and providing more seamless nondisruptive failover in the event that an OSA port in the group becomes unavailable
- Enhanced failover support for IPv4 and IPv6 devices
- VIPA support for IPv6
- New LDAP server and associated client utilities
- Enhanced system security with support for longer passwords (password phrases)
- Tape data protection with support for encryption
  - Encryption Re-Key support provides the capability to update a previously encrypted tape cartridge with a new set of Key Encryption information to help allow for a continuous protection of tape cartridge data with the PTF for APAR VM64260.

#### **z/VM Version 5 Release 2 provides:**

- Enhanced exploitation of real memory beyond 2 GB
- Improved memory management algorithms to help benefit paging workloads with large memory environments with the PTF for APAR VM64349
- Enhanced performance assist for cooperating z/VM guests using OSA-Express, FCP, and HiperSockets
- Definition and operation of FCP-attached SCSI disks

with capacities of approximately 1 TB with the PTFs for APARs VM63700 and VM63664

- Guest exploitation of the System z10 EC at the level of System z9 functionality with the PTFs for APARs VM64180 and VM64242
- Exploitation of selected functions of the System z10 EC including the capability for:
  - TCP/IP and VSWITCH gaining the performance benefit of OSA-Express3 10 GbE on the z10 EC
- Exploitation of selected features of the z9 EC and z9 BC
  - Support for new instructions<sup>1</sup>
  - Support for FICON Express4 (4 Gbps FICON)
  - TCP/IP and guest LAN Support for HiperSockets using IPv6 protocol<sup>1</sup>
  - Simplified VLAN management with support for GVRP<sup>1</sup>
  - Crypto Express2 Accelerator for SSL acceleration
  - Support for OSA-Express2 OSN (OSA for NCP)
  - Enhanced FCP channel utilization and sharing among guests through NPIV support
  - Support for hardware capability to add and delete LPAR names
  - Support for hardware capability to provide up to 60 LPARs on the z10 EC, z9 EC, and 30 on the z9 BC
- Additional exploitation of the IBM DS6000 and DS8000 series<sup>1</sup>
- Support for Logical Volume Expansion simplifying disk management by allowing for the dynamic increase of a DS8000 volume size in order to accommodate application data growth with the PTFs for APARs VM64305 and VM64354
- Support for Parallel Access Volumes (PAVs) as minidisks<sup>1</sup>

Notes: <sup>1</sup> - Requires the PTF for APAR VM63952

### **z/VM provides support for running Parallel Sysplex system environments**

- z/OS, and z/OS.e Parallel Sysplex® system environments as z/VM guests
- Virtual Coupling Facility (CF) support:
  - Helps provide faster deployment of new Parallel Sysplex systems through testing with virtual sysplexes
  - Does not require or support real hardware coupling facilities and coupling links
  - Support Coupling Facility duplexing with System z
  - Allows z/VM systems hosting sysplexes to run as second-level (or higher) guests
  - Help reduce risk in running new applications for z/OS or z/OS.e releases
  - Helps reduce problems in scheduling test and production time
  - Helps reduce training expense and risk to production operations through operator training with virtual configurations
  - Provides additional options for disaster recovery
- z/VM V5 supports the Parallel Sysplex guest environment on all models of the IBM z10 EC, z9 EC, z9 BC, z990, z900, z890, and z800 servers.

### **z/VM encompasses many uses**

- Flexible, cost-effective guest environments
- Well-suited for on demand business
- Consolidation of select UNIX® and Linux workloads onto a single physical hardware server
- Data and application serving for Internet/intranet users
- Rich application development environment

### **z/VM for On Demand Business**

- Access to enterprise data and applications through TCP/IP NFS
- Enterprise Web serving through IBM Business Partner products working cooperatively with z/VM
- Reusable Server Kernel (RSK) for vendors and application programmers to write multithreaded server programs

### **VM installation and service tools**

- Virtual Machine Serviceability Enhancements Staged/Extended (VMSES/E) available for:
  - Installation of z/VM, IBM Licensed Products, and vendor products in VMSES/E format
  - Allows the service disks of the z/VM components to reside in SFS
  - Application of z/VM service
    - CORrective service (COR)
    - Recommended Service Upgrades (RSU)
- z/VM installation and service available on CD-ROM (except with V5.2 and later)
- Installation available on 3590-formatted tapes and DVD on V5.2 and later
- Order z/VM products and service using ShopzSeries
  - Internet delivery of z/VM SDO licensed products

To learn more about ShopzSeries:

---

[ibm.com/software/ShopzSeries/](http://ibm.com/software/ShopzSeries/)

---

## **CMS Interactive Support**

### **CMS application multitasking**

- Applications can be divided to handle work in parallel
- Application throughput can be improved
- POSIX exploits CMS multitasking
- CMS Pipelines support the use of CMS multitasking

### **CMS Pipelines**

- Programmer productivity tool for simple creation of powerful, reusable REXX and Assembler programs and Common Gateway Interface (CGI) scripts for Web servers

### **Data-in-memory exploitation**

- Virtual disk in memory provides fast access to data in memory
- Minidisk cache boosts performance with cache in main and/or expanded storage (memory)
- VM Data Spaces allow applications in virtual machines to create additional VM data spaces of 2 GB, up to 2 TB total

### **Callable Services Library (CSL)**

- Enhanced application development productivity
- REXX and other high-level languages can use z/VM services, such as requesting Shared File System functions
- Interfaces to use VM data spaces
- Interfaces to POSIX functions for CMS users and applications

### **CMS Binder/Loader for z/VM**

- Enhanced application affinity between CMS, z/OS, or z/OS.e
- The CMS binder
  - Creates and utilizes data spaces if the user is authorized
  - Converts object or load modules, or program objects, into a program object and stores the program object in a partitioned data set extended (PDSE) program library
  - Converts object or load modules, or program objects, into a load module and stores the load module in a partitioned data set (PDS) program library
  - Converts object or load modules, or program objects, into an executable program in virtual memory and executes the program
- The CMS loader
  - Increases the services of the program fetch component by adding support for loading program objects
  - Reads both program objects and load modules into virtual storage and prepares them for execution

### **VMLINK**

- User productivity enhancer for linking minidisks and SFS directories
- Rewritten for enhanced serviceability in z/VM

---

[ibm.com/eserver/zseries/zvm](http://ibm.com/eserver/zseries/zvm)

---

## VM Server Support

### VM Data Spaces are designed to:

- Offer capabilities unique to System z family
- Provide high speed transfer and data access between virtual machines, helping to improve throughput and response times
- Allow applications to address multiple 2 GB data spaces
- Support data sharing between a server and multiple users
- Provide an application programming interface and Callable Services Library routines, exploited by DB2<sup>®</sup> for VSE and VM, SFS and FORTRAN to help
  - Enable customers and vendors to develop applications using VM Data Spaces
  - Make development process easier

### z/VM Shared File System (SFS) is designed to:

- Allow read/write sharing at the file level
  - Provide sharing within one system or across multiple systems
  - Provides file security through authorization mechanism

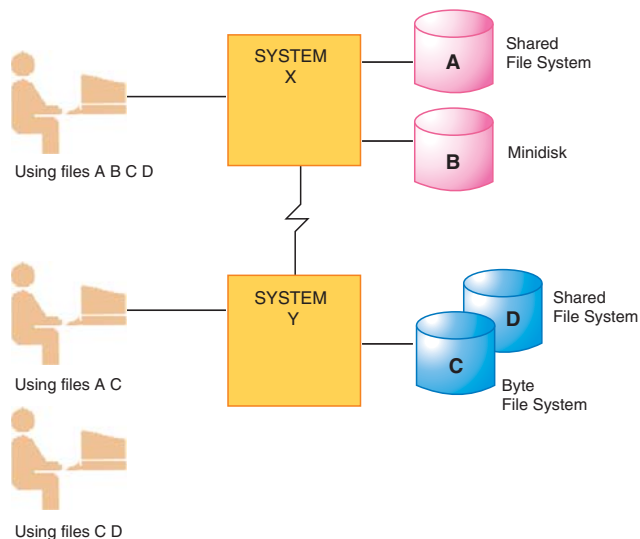

- Improve performance
  - Utilizes minidisk caching in main or expanded storage memory
  - Exploits VM Data Spaces
- Improve usage of disk storage devices
  - Store data stored in file pools
  - Provides logical vs. physical allocation of data blocks
  - Makes unused blocks available to any user of file pool
- Improve productivity
  - Organizes files in hierarchical directories
  - Supports aliases for file names
  - Provides single application interface via CSL routines for SFS and minidisk data
- Simplify system administration
  - Provides file pool backup and file-level restore
  - Provides dynamic expansion of file space for users
  - Provides dynamic expansion of DASD to file pool
  - Allocates file pool DASD space vs. individual minidisks
  - Allow the same administration tools to be used for POSIX hierarchical byte file system files
- Use Coordinated Resource Recovery
  - Coordinates updates to multiple file pools
  - More easily developed distributed applications, with system coordination of data integrity
- Enable access to distributed data
  - Transparent access to remote data
- Allow CMS users and applications to access the POSIX hierarchical byte file system
- Shuts down automatically when the z/VM Control Program (CP) is shutdown

## Guest Operating System Support

### DFSMS/VM is designed to:

- Provide automated space management
  - Space management for Shared File and Byte File System files
  - Migration, recall and expiration of active and inactive data
  - Archive/restore of SFS files to tape with Tivoli Storage Manager
- Provide a high-performance data mover
  - Enables fast migration to new storage devices
  - Near 1 TB SCSI disk support
- Include Interactive Storage Management Facility (ISMF)
  - Provides consistent interface for VM, z/OS or z/OS.e storage administrators
  - Assists in managing minidisk data
- Manage IBM TotalStorage Virtual Tape Server (VTS) 3494 tape libraries containing 3480, 3490, 3590, and 3592 drives
  - Includes support for Write Once Read Many (WORM) data cartridges
- Provide the capability for a tape-librarian product to communicate with an automated tape library
- Provide ATL access for VSE guests
- Provide multi-user attach support allowing z/VM to be installed from 3490 tapes residing in an ATL (requires the PTF for APAR VM63746)
- Provide tape encryption support for z/VSE guests with the PTF for VM64062
- Be orderable as a no-charge feature with the z/VM V5 SDO

---

[ibm.com/eserver/zseries/zvm/related/dfsms/](http://ibm.com/eserver/zseries/zvm/related/dfsms/)

---

The z/VM hypervisor concurrently supports many different virtual machines, each running its own operating environment (“guest” operating system) with security and isolation features.

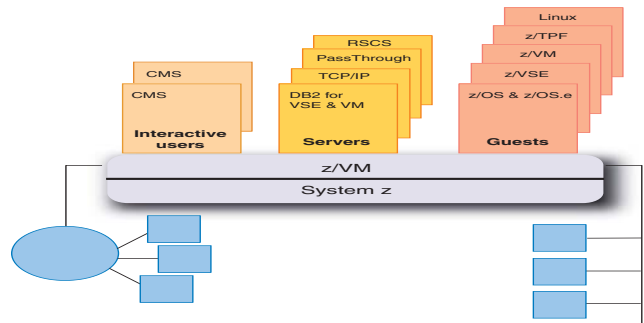

### Linux on System z potential guest benefits

- Consolidation of Linux workloads on a single physical hardware server
  - Allows multiple Linux images on a z/VM system running IFLs processors without affecting IBM software charges for existing System z standard processors in the same hardware server
  - Improved memory management algorithms to help benefit paging workloads with large memory environments with the PTF for APAR VM64349
- Enhanced exploitation of real memory beyond 2 GB
- Support for the Collaborative Memory Management Assist (CMMA), by which host and guest exchange information to optimize their use and management of memory (Refer to the z/VM V5.3 Performance Report for CMMA usage.)
- Enhanced memory utilization using VMRM between z/VM and Linux
- Shared disk resources creating a server farm within a single machine
- More Linux images operating concurrently with reduced contention on the VM scheduler lock for better performance
- High-performance networking among virtual machines

- Enhanced operation and support for additional Linux distributions with upgraded SSI server
- Support for OSA-Express2 and OSA-Express3 OSN (OSA for NCP)
- Enhanced performance assists for cooperating z/VM guests using OSA-Express, FCP, and HiperSockets
- Enhanced problem determination for guest LANs and virtual switches
- VSWITCH support for IEEE 802.3ad link aggregation and failover support
- Guest support for dedicated QDIO devices (HiperSockets, OSA-Express, and FCP channels)
- Attachment of SCSI devices using the System z FCP feature of all FICON Express adapters
  - Point-to-Point Fibre Channel links
  - Dynamically-determined preferred paths for emulated FBA devices (EDEVICEs) on SCSI disks in an IBM System Storage DS6000
  - Faster formatting of EDEVICEs on SCSI disks
  - Display of additional SCSI device characteristics
  - Guest IPL from SCSI FCP disks on servers equipped with the SCSI IPL Feature Enabler
  - Deploy a Linux server farm on z/VM using only SCSI FCP disks
  - Enhanced performance of z/VM Control Program (CP) use of SCSI disk I/O
  - Enhanced FCP channel utilization and sharing among guests with NPIV support
- Support for the IBM System Storage SVC Storage Engine 2145 allows Linux on System z guests of z/VM V5 (all releases) to access IBM System Storage disk subsystems, including the DS4000 series, and OEM SCSI disk devices supported by the SVC. SCSI disk devices supported as emulated FBA devices for use by CP and guest operating systems is provided for z/VM V5.3 and z/VM V5.2 (with the PTF for APAR VM64128).
- z/VM HyperSwap function to help provide a coordinated near-continuous availability and disaster recovery solution for distributed applications, such as WebSphere®, that can span z/OS images running natively and Linux guests running under z/VM
- Publication for deploying Linux on System z with z/VM
- Performance Toolkit enhancements to add new high-level Linux reports and monitor records
- Simplified systems management using facilities provided by z/VM
- Systems management API for client applications to allocate and manage resources for virtual machines
- z/VM systems management functions to be performed from the HMC to manage guests without having to establish any network connections or carry out complex configuration of the system
  - IBM intends to further enhance z/VM in a future release to exploit the new Hardware Management Console (HMC) interface that allows the installation of Linux on System z into a z/VM virtual machine. Additionally, future support is planned for z/VM and the HMC to provide z/VM hypervisor-configuration tasks.
- Handling of unexpected workload growth by the quick addition of Linux virtual machines as needed
- Enhanced device support, such as virtual disks and peer-to-peer remote copy for Linux systems
- More flexible data transfer with virtual switch exploitation of Layer 2 support for OSA-Express, OSA-Express2, and OSA-Express 3
- Increased number of TCP/IP stacks
- With corresponding function from Linux on System z, Linux guest virtual machines may benefit from:
  - Enhanced page-fault handling
  - Guest support for the IBM PCI Cryptographic Coprocessor (PCICC) or the IBM PCI Cryptographic Accelerator (PCICA)

- *Dedicated-queue and shared-queue support for clear-key cryptographic functions*
- *Guest support for the PCIX Cryptographic Coprocessor (PCIXCC) feature*
  - *Dedicated-queue and shared-queue support for clear-key cryptographic functions*
- *Guest support for the Crypto Express2 feature (coprocessor and accelerator)*
  - *Dedicated-queue and shared-queue support for clear-key cryptographic functions*
- *Enhanced disk-access performance with minidisk cache*
- *Facilities to back up all Linux data providing a single backup solution for all Linux servers*
- *Strong tracing, diagnostic and debugging facilities*
- *Access to a large number of Linux applications*

#### **z/VSE and VSE/ESA potential guest benefits**

- *A state-of-the-art platform for combining the best of VSE core applications with new workloads that exploit Linux on System z*
- *Outstanding operational flexibility, simplicity, and productivity:*
  - *Multiple specialized VSE guests for test, development, and release-to-release transition*
  - *Multiple production VSE guests for system simplicity*
  - *Integration of VSE and Linux guests for server consolidation and new workloads, including WebSphere Application Server*
- *Improved performance with:*
  - *Virtual disk-in-memory exploitation, for example, shared lock file*
  - *Minidisk caching in expanded and main storage (memory)*
  - *DB2 for VSE & VM data sharing for enhanced performance*
  - *IBM TotalStorage Virtual Tape Server 3494 automated tape library access*

#### **z/OS and z/OS.e potential guest benefits**

- *Parallel Sysplex support for guests within a single VM image*
  - *Virtual Coupling Facility support to allow z/VM systems to run as first or second-level, or higher guests while simulating complete z/OS and/or z/OS.e coupled sysplexes*
- *Testing environment for deploying applications on simulated zAAP and zIIP specialty processors*
- *Testing environment for deploying applications on real zAAP and zIIP specialty processors*
- *Modified Indirect Data Address Words (MIDAWs) to allow more flexibility and performance in certain channel programs as an alternative to data-chained channel-command words*
- *z/VM HyperSwap function to help provide a coordinated near-continuous availability and disaster recovery solution for distributed applications, such as WebSphere, that can span z/OS images running natively and Linux guests running under z/VM*
- *Guest support for the PCICA feature*
  - *Dedicated-queue support for clear-key cryptographic functions*
- *Guest support for the PCICC feature*
  - *Dedicated-queue support for clear-key and secure-key cryptographic functions*
- *Guest support for the PCIXCC feature*
  - *Dedicated-queue support for clear-key and secure-key cryptographic functions*
- *Guest support for the Crypto Express2 feature (coprocessor and accelerator)*
  - *Dedicated-queue support for clear-key and secure-key cryptographic functions*
  - *Guest support for Parallel Access Volumes (PAVs)*

## Performance

### Support for z/Architecture and ESA/390-mode operating systems

- *Performance assist support*
  - *Adapter interruption performance assist for QDIO*<sup>1</sup>
  - *QDIO Enhanced Buffer State Management (QEBSM) and Host Page Management Assist (HPMA)*<sup>2</sup>
- *Potential for hundreds to thousands of guests for migration, testing, production, and development*
- *Virtual device support*
- *Shared and dedicated resources*
- *Memory-management assist*
- *Debugging and trace facilities for guest systems*
- *64-bit guest operating systems including z/OS, z/OS.e, z/VSE and Linux on System z*

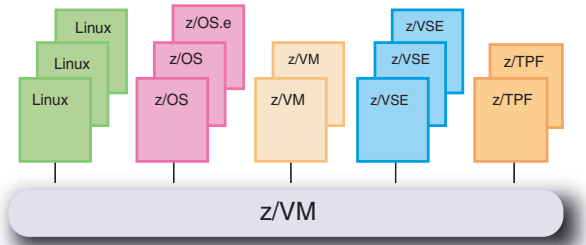

#### Notes:

- 1) This performance assist is available only on the z10 EC, z9 EC, z9 BC, z990, and z890.
- 2) QEBSM and HPMA are supported by z/VM V5.2 and later releases and are exclusive to the z9 EC and z9 BC.

Note: z/OS.e is available only in LPAR mode on the z9 BC, z890 or z800 and must run in a logical partition, either alone or as a guest of z/VM. You may not run z/OS as a guest of a z/VM system in which z/OS.e is also a guest per licensing agreements of z/OS.e.

z/VM offers many features that can help improve performance. A number of these features work by keeping frequently used data in memory, thus significantly reducing repeated I/O for the same data. The reduction in I/O can result in faster response times, improved processor efficiency and reduced load on the I/O subsystem. Minidisk caching and virtual disk in storage are two examples of the use of data-in-memory techniques in z/VM.

The degree of benefit varies with the frequency of system workload I/O that applies to these techniques, data-reference patterns, disk configuration, memory availability, and other factors.

To learn more about z/VM performance:

---

[ibm.com/eserver/zseries/zvm/perf/](http://ibm.com/eserver/zseries/zvm/perf/)

---



## Connectivity Options

### Networking options

z/VM provides a wide range of networking and connectivity options and adheres to many of the industry standards, enabling communications across distributed heterogeneous environments. Examples include:

- SNA
- BSC
- TCP/IP
- X.25
- Token-Ring
- Ethernet (GbE, 10 GbE, and 1000BASE-T)
- X-Windows
- Network File Systems
- Simple Mail Transfer Protocol
- IP Multicast
- X.400 mail exchange protocol
- NJE

### Network management

- SNA and TCP/IP networks

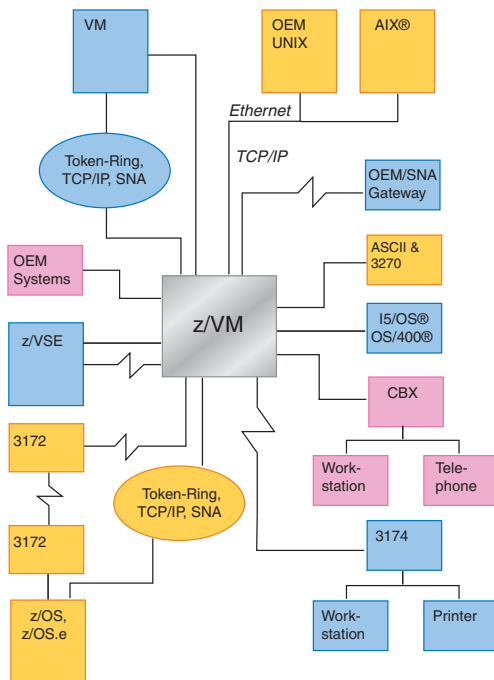

## Communication Products

### TCP/IP for z/VM V5.3 (Level 530)

- All functions available in TCP/IP for z/VM for z/VM V5.2 plus:
  - z/VM SSL server support for additional Red Hat and Novell SUSE Linux distributions
  - Enhanced ease-of-use for virtual networks
  - Enhanced failover support for IPv4 and IPv6 devices
  - Virtual IP Address (VIPA) support for IPv6
  - New LDAP server and associated client utilities
  - Enhanced security with the z/VM SSL server
  - Performance benefit of OSA-Express3 10 GbE on z10 EC

Note: Operates with z/VM V5.3

### TCP/IP for z/VM V5.2 (Level 520)

- All functions available in TCP/IP for z/VM for z/VM V5.1 plus:
  - SSL server support for Red Hat and additional SUSE Linux distributions
  - Enhanced problem determination for guest LANs and virtual switches
  - Enhanced dynamic routing capabilities with a new MPRRoute server
  - TCP/IP and guest LAN Support for HiperSockets using IPv6 protocol with the PTF for APAR VM63952
  - Simplified VLAN management with support for GVRP with the PTF for APAR VM63952
  - Performance benefit of OSA-Express3 10 GbE on z10 EC

To learn more about TCP/IP for z/VM:

[ibm.com/eserver/zseries/zvm/related/tcpip](http://ibm.com/eserver/zseries/zvm/related/tcpip)

### ACF/VTAM Version 4 Release 2 for VM/ESA

- Enhanced growth and constraint relief
- Increased number of users connected to a single VTAM® image
- Larger, more functional, less complex networks

- APPN® capability
- Low End Networking (LEN) communications to all nodes
- Better interconnection with multivendor networks
- Increased performance for on-line transaction processing
- Enhanced client/server access
- More flexible access to applications and resources across multiple platforms

(See VTAM V4.2 for VM/ESA Release Guide – GC31-8089)

---

[ibm.com/software/network/vtam](http://ibm.com/software/network/vtam)

---

### **RSCS FL530 optional feature of z/VM (V5.3 only)**

- All functions available with RSCS Version 3 Release 2 plus:
  - Repackaged as a priced, optional IPLA feature for operation on IFL and standard processors
  - Dynamic command authorization support eliminating the need to re-cycle RSCS when changing system and link authorizations

(See z/VM V5R3.0 RSCS Networking Operation and use - SC24-6154)

---

[ibm.com/eserver/zseries/zvm/related/rscs](http://ibm.com/eserver/zseries/zvm/related/rscs)

---

### **RSCS Version 3 Release 2 (V5.2)**

- Provides unsolicited File Transfer (UFT) client and daemon support
- Processes NJE data traffic over TCP/IP, SNA, Bisynchronous, or directly-attached systems (CTCA, ESCON® and FICON)
- Provides print support to TCP/IP printer daemon in text and PostScript format
- Supports ASCII printers attached to protocol converters or by TCP/IP connection
- Enables RSCS server to be the z/VM daemon to the TCP/IP world

- Enables the z/VM printer daemon to access any printer attached directly or indirectly to the NJE or TCP/IP network
- Provides API interface to code your own device drivers for RSCS
- Is easy to customize, maintain and use

Note: RSCS V3.2 is planned to be withdrawn from marketing on May 26, 2008

(See VM RSCS General Information Guide – GH24-5218)

---

[ibm.com/eserver/zseries/zvm/related/rscs](http://ibm.com/eserver/zseries/zvm/related/rscs)

---

### **VM/Pass-Through Facility Version 2**

- Multisession support for CMS and dialed users
- Auto sign-on support
- FICON Express4, FICON Express2, FICON, ESCON, TCP/IP, APPC, IUCV, CTCA, 3088, Binary-synchronous connectivity options
- Gateway access to SNA network
- Connectivity to other VM, z/OS, z/OS.e, VSE, z/VSE and AIX® systems
- Automated session operations
- Transparent, seamless solutions for end-users
- Sharing a single session among multiple workstations
- Help with low-cost workstation support for VSE guest virtual machines
- Screen-capture capabilities
- Direct support for SDLC terminal control units
- Cross-system IUCV support provides communications path for applications on separate VM systems to use IUCV protocols

(See VM/Pass-Through Facility Users Guide – SC24-5555)

---

[ibm.com/eserver/zseries/zvm/related/pvm](http://ibm.com/eserver/zseries/zvm/related/pvm)

---

## z/VM Decision Support

VM has multiple offerings that enable the end user to transform business data into timely and accurate business decisions.

### DB2 Server for VSE & VM

- Can help improve productivity with Stored Procedures
- Exploits DRDA® 2 in application server for accessibility to data on local or remote systems
- DB2 access over a TCP/IP network from DRDA requesters
- Increased database availability with Incremental Archive
- Optional QMF™ and QMF for Microsoft® Windows® features
- Enables database switching
- Allows multiple read-only users access to all data
- Provides VM database access from VSE system
- Recovery of databases at the table and storage pool level
- Supports VM Data Spaces
- Optional database administration feature

### DB2 Server for VSE & VM V7.5

- New release provides an enhanced client offering to:
  - Provide bind file support for VSE and VM
  - Provide Runtime only Client edition for VSE
  - Provide Runtime only Client edition for VM
  - Convert all online phases to AMODE 31 RMODE ANY
  - Plus other additional functional enhancements

(See DB2 Server for VSE & VM Overview – GC09-2995)

---

[ibm.com/software/data/db2/vse-vm/](http://ibm.com/software/data/db2/vse-vm/)

---

### Query Management Facility (QMF) Feature

- Provides easy-to-use workstation GUI interfaces
- Powerful query and report writer for DB2 data
- Client/server capabilities for the workstation environment
- Processes both relational and non-relational data
- Connect to DB2 for Linux on System z as an application server

(See Using QMF 7.2 – SC27-0716, and QMF 7.2 Reference Guide – SC27-0715)

---

[ibm.com/software/data/qmf/](http://ibm.com/software/data/qmf/)

---

## Open Computing

### POSIX standards

- Extend portability and provides standards-based application-development services
- Define basic operating-system interfaces and behavior
- POSIX 1003.1c threads – Provide a general set of services for developing multitasking server applications that support multiple, concurrent execution streams
  - POSIX 1003.1c
  - POSIX 1003.1 and POSIX 1003.1a
  - POSIX 1003.2 – Shell and Utilities
- POSIX hierarchical byte file system support by CMS and SFS enables access by heterogeneous systems across LANs and WANs

(See z/VM OpenExtensions Users Guide — SC24-6108)

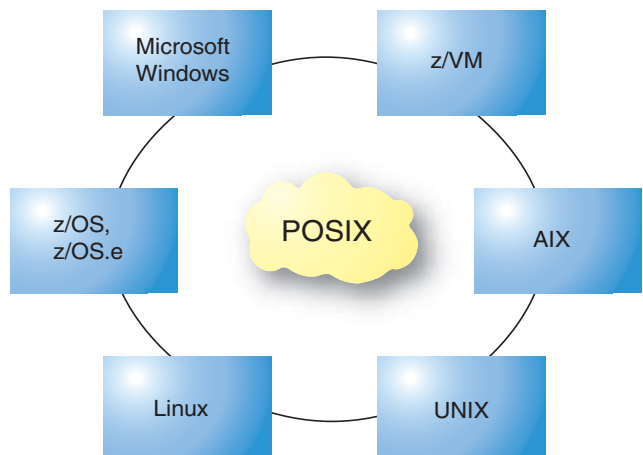

Notes:

- 1) The OpenExtensions Shell and Utilities is packaged with z/VM at no additional charge
- 2) DCE is not available in z/VM V5.

## **z/VM System Management Products**

### **Performance Toolkit for VM FL530 optional feature of z/VM**

Provides enhanced capabilities for a z/VM systems programmer, operator, or analyst to monitor and report performance data:

- Full-screen-mode system-console operation
- Management of multiple z/VM systems (local or remote)
- Post-processing of Performance Toolkit for VM history files and of VM monitor data captured by the MONWRITE utility
- Performance monitoring
- Viewing of performance monitor data using either Web browsers or PC-based 3270 emulator graphics
- TCP/IP performance reporting
- Processing of Linux performance data obtained from RMF™ which can be viewed and printed similar to the way VM data is viewed and presented
- Reporting for Linux and SCSI FCP disks
- Performance Toolkit server does not have to be shut down and restarted when adding new VM systems within the enterprise for performance-data retrieval
- Support for passphrases when accessing the Performance Toolkit's Web interface
- Change the service process for the Performance Toolkit from a full-part replacement MODULE to service by individual object parts, reducing the size of the service deliverable
- New or updated displays and reports to support new V5.3 functions
- Functional equivalence to PRF and RTM

(See z/VM: Performance Toolkit for VM - SC24-6136 for V5)

---

[ibm.com/eserver/zseries/zvm/perf/toolkit](http://ibm.com/eserver/zseries/zvm/perf/toolkit)

---

### **Directory Maintenance (DirMaint) FL530 optional feature of z/VM V5.3**

- Reduces indefinite wait times when a DATAMOVE machine cannot access all required resources for a DASD management function
- Provides a security-rich interactive facility for maintaining the system directory
- Simplified user administration with the coordination of DirMaint and RACF changes with z/VM V5.2 and later
- Enhanced directory management performance with z/VM V5.2 and later
- Provides distributed administration
- Provides commands and exits to support new functions
- Supports Systems Management APIs
- Supports the Shared File System
- Enables VMSES/E installation and service

(See DirMaint Facility Tailoring and Administration Guide – SC24-6135)

---

[ibm.com/eserver/zseries/zvm/related/dirmaint](http://ibm.com/eserver/zseries/zvm/related/dirmaint)

---

### **Resource Access Control Facility (RACF) Security Server FL530 optional feature (z/VM V5.3 only)**

- Includes function of the RACF for z/VM optional feature plus:
- Interoperates with the new z/VM V5.3 TCP/IP LDAP server
- Supports mixed-case passwords and passwords that are longer than eight characters, called password phrases (also known as passphrases)
- Release-specific priced, optional feature, operating only with z/VM V5.3

(See z/VM: RACF Security Server General User's Guide — SC24-6146)

### **RACF for z/VM optional feature (z/VM V5.2)**

RACF helps meet the need for security by providing:

- Flexible control of access to protected resources
- Protection of installation-defined resources
- Ability to store information for other products
- Choice of centralized or decentralized control of profiles
- Designed to provide transparency to end users

Note: Operates on V5.2

(See RACF General Information — GC28-0722)

---

[ibm.com/eserver/zseries/zos/racf/vm.html](http://ibm.com/eserver/zseries/zos/racf/vm.html)

---

### **IBM Tivoli zSecure Manager for RACF z/VM**

Combines capabilities of the most used zSecure Audit and Admin functions for the virtual machine environment to:

- z/VM security management tasks with simple, one-step actions that can be performed without detailed knowledge of RACF command syntax
- Quickly identify and prevent problems in RACF before they become a threat to security and compliance
- Help ease the burden of database consolidation
- Create comprehensive audit trails without substantial manual effort
- Generate and view customized audit reports with flexible schedule and events elections

(See IBM Tivoli zSecure Manager for RACF z/VM: Installation and Configuration Manual -- SC23-6574)

[ibm.com/software/tivoli/products/zsecure-mgr-zvm-racf/](http://ibm.com/software/tivoli/products/zsecure-mgr-zvm-racf/)

### **CMS Utilities Feature (CUF)**

- Integrated into z/VM Version 4 at no additional charge
- Complements the CMS interactive support

- Can increase the productivity of your local operations
  - Provides tools and services that simplify and enhance the operation of CP and CMS environments for end users and application developers
  - Provides fully-supported commands, EXECs and applications that would otherwise need to be created locally
  - ACCOUNT updates to recognize specialty processors

---

[ibm.com/eserver/zseries/zvm/related/cuf](http://ibm.com/eserver/zseries/zvm/related/cuf)

---

### **Host Management Facilities/VM**

- Monitors subsystems and applications to help reduce outages
- Coordinates and simplifies performance analysis
- Enables increased console automation
- Manages local and remote systems
- Enables automation of subsystem and application management
- Enables VMSES/E installation and service

(See Host Management Facilities/VM General Information Manual – SC24-5612)

---

[ibm.com/eserver/zseries/zvm/related/hmf](http://ibm.com/eserver/zseries/zvm/related/hmf)

---

### **Additional Product Information**

For additional information on the many z/VM technology-related products from IBM and independent software vendors, visit the z/VM Web site at:

---

[ibm.com/eserver/zseries/zvm/products/](http://ibm.com/eserver/zseries/zvm/products/)

---

## Configurability

### Partitioning Options

Virtual	Logical
---------	---------

### Number of Images

Many	15 - 60 <sup>1</sup>
------	----------------------

### Performance

– Adapter-interruption performance assist for QDIO <sup>3</sup> - high performance for V=V guests using QDIO (HiperSockets, OSA-Express, and FCP)	Near Native
– QDIO performance assists <sup>4</sup> (QEBSM, and HPMA - high performance for V=V guests using QDIO (HiperSockets, OSA-Express, and FCP)	

### Resources

– Dedicated or shared processors, memory and devices	– Dedicated or shared processor
– Virtual devices	– Dynamic memory reconfiguration
	– Dedicated channels, CUs and devices <sup>2</sup>

### Support Requirements

Hardware and Software	Hardware
-----------------------	----------

### Reliability

Hardware and Software	Hardware
-----------------------	----------

1. Server-dependent (up to 15 on z900 and z800, up to 30 on the z9 BC, z990 or z890, and up to 60 on the z10 EC, z9 EC servers).
2. Channels (except parallel) may be shared on System z and S/390 servers using the Multiple Image Facility (MIF).
3. Adapter-interruption performance assist is available only on z10 EC, z9 EC, z9 BC, z990, and z890 servers;
4. QEBSM and HPMA are available only on z9 EC and z9 BC servers.

## VM Evolution

- z/VM Version 5 supports the z10 EC, z9 EC, z9 BC, z990, z890, z900, and z800 (standard, IFL, zAAP, and zIIP processors) in z/Architecture mode.

Note: For information on versions of VM prior to z/VM V5, refer to the z/VM Reference Guide GM13-0137.

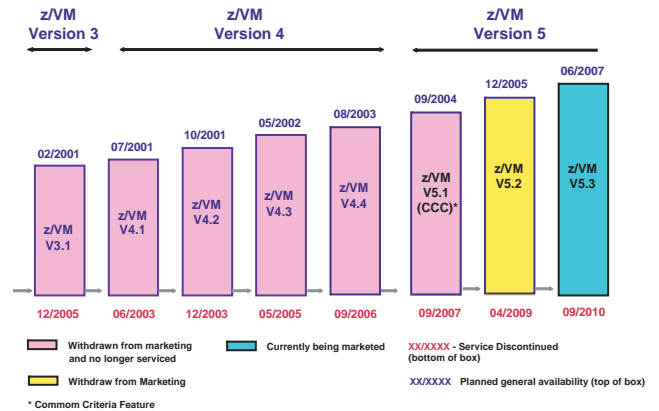

## VM Operating System Comparison

VM Function	z/VM V4 <sup>24</sup>	z/VM V5
<b>Function</b>		
Shared File System	•	•
Callable Services Library	•	•
Cross Systems Extensions	•	•
Virtual disk in memory	•	•
Enhanced minidisk cache	•	•
370 accommodation	•	•
CP Exit Facility	•	•
Parallel Sysplex simulation	•	•
Coupling Facility duplexing <sup>3</sup>	•	•
HiperSockets <sup>3</sup>	•	•
IPv6 HiperSockets <sup>7,8</sup>	-	•
GVRP Support <sup>6,8</sup>	-	•
Guest LAN <sup>3</sup>	•	•
Guest LAN Sniffer <sup>7</sup>	-	•
MRoute Server <sup>7</sup>	-	•
Shared tape for guests <sup>4</sup>	•	•
Accounting enhancements	•	•
Systems management APIs <sup>5</sup>	•	•
HMC integrated systems management <sup>9</sup>	-	•
VMRM enhancements <sup>5</sup>	•	•
Virtual LAN <sup>5</sup>	•	•
Virtual SWITCH (VSWITCH) <sup>5</sup>	•	•
VSWITCH support for link aggregation <sup>9</sup>	-	•
HCM and HCD <sup>5</sup>	•	•
MQ Interface Client	•	•
PCIX Cryptographic Coprocessor <sup>6</sup>	-	•
Crypto Express2 <sup>6</sup>	-	•
LDAP server and client utilities <sup>9</sup>	-	•
Password phrases (Passphrases) <sup>9</sup>	-	•
Dynamic Virtual Machine Timeout <sup>6</sup>	-	•
VMRM enhancements for memory management of Linux guests <sup>9</sup>	-	•
CMMA <sup>9</sup>	-	•
Guest ASCII console <sup>9</sup>	-	•
Enhanced virtual network management providing SNMP data <sup>9</sup>	-	•
Enhanced failover support for IPv4 and IPv6 devices <sup>9</sup>	-	•
VIPA support for IPv6 <sup>9</sup>	-	•
Storage Relief below 2 GB <sup>7</sup>	-	•
LPARs up to 256 GB <sup>9</sup>	-	•
Up to 32 real processors per LPAR <sup>9</sup>	-	•
<b>Central Storage (Memory)</b>		
32 GB (z890 and z800)	•	•
64 GB (z900)	•	•
64 GB (z9 BC)	•	•
256 GB (z990)	•	•
512 GB (z9 EC) <sup>5</sup>	•	•
1520 GB (z10 EC) <sup>7</sup>	-	•
<b>Expanded Storage (Memory)</b>		
Paging	•	•
Guest	•	•
VM Data Spaces	•	•
<b>Virtual Machine Size</b>		
256 GB <sup>1</sup>	•	•
1 TB (Processor dependent) <sup>9,25</sup>	-	•

VM Function	z/VM V4 <sup>24</sup>	z/VM V5
<b>I/O</b>		
FICON/ESCON I/O	•	•
FICON CTCA <sup>3</sup>	•	•
FICON Express2	•	•
FICON Express4	•	•
Parallel Access Volumes (PAVs) as minidisks <sup>5</sup>	-	•
Virtual FICON CTCA <sup>5</sup>	•	•
Cascaded FICON Directors <sup>5</sup>	•	•
Guest use of FCP <sup>4</sup>	•	•
Guest use of emulated SCSI FCP disks <sup>5</sup>	-	•
CP use of SCSI FCP disks <sup>22</sup>	-	•
N-Port Identifier Virtualization <sup>23</sup>	•	•
Guest use of MIDAWs <sup>9</sup>	-	•
Logical Channel SubSystems <sup>5</sup>	•	•
HyperSwap <sup>6</sup>	-	•
OSA-Express2 OSN <sup>7</sup>	-	•
OSA-Express3 <sup>7</sup>	-	•
<b>Guest Operating System</b>		
S/370™ architecture	•	•
370-XA architecture	•	•
ESA/390 architecture	•	•
z/Architecture	•	•
<b>Performance Assists</b>		
I/O Assist <sup>2,20</sup>	•	•
Adapter interruption performance assist for QDIOAssist <sup>5,21</sup>	•	•
QEBSM and HPMA <sup>7,21</sup>	-	•
<b>Systems/Processor Units Supported</b>		
System z10 EC <sup>7</sup>	-	•
System z9 EC/z9 BC <sup>6</sup>	•	•
zSeries 800/890/900/990 Servers <sup>#</sup>	•	•
G5/G6 Servers	•	•
IFLs	•	•
zAAPs <sup>9</sup>	-	•
zIIPs <sup>9</sup>	-	•

### Legend

- 1 Pageable guests only
  - 2 The sum of memory for each of the preferred guests plus the memory required for the VM Control Program cannot exceed 2 GB
  - 3 Supported on z/VM V4.2 and later
  - 4 Supported on z/VM V4.3 and later
  - 5 Supported on z/VM V4.4 and later
  - 6 Supported on z/VM V5.1 and later
  - 7 Supported on z/VM V5.2 and later
  - 8 Requires PTF for VM63952 on z/VM V5.2
  - 9 Supported on z/VM V5.3 and later
  - 20 I/O - assist is not available when z/VM is running in a logical partition. z/VM must be run in a logical partition on the z890, z990, z9 EC and z9 BC.
  - 21 Adapter-interruption performance assist is available only on z10 EC, z9 EC, z9 BC, z990, and z890 servers; QEBSM and HPMA are available only on z10 EC, z9 EC and z9 BC
  - 22 For installation, IPL, and operation of z/VM V5
  - 23 z/VM V4.4, and V5 enables guest use of NPIV when FCP subchannels are dedicated to a guest. V5 provides for CP use of NPIV
  - 24 Withdrawn from Marketing
  - 25 Supported on the z10 EC, z9 EC and z9 BC
- Supported  
 - Not applicable  
 # No 370-mode execution

## VM Feature Comparison

VM Function	z/VM V4 <sup>22</sup>	z/VM V5
REXX Sockets	•	•
31-bit CMS	•	•
CMS Pipelines	•	•
CMS multitasking	•	•
Reusable Server Kernel	•	•
POSIX	•	•
DCE	•	-
Binder/Loader	•	•
NFS Client	•	•
<b>APPC</b>	•	•
<b>Shared File System</b>	•	•
VM Data spaces	•	•
Common SFS and minidisk interface	•	•
POSIX Byte File System	•	•
Automated SFS shutdown <sup>5</sup>	•	•
<b>DFSMS/VM</b>	•	•
Fast data mover	•	•
Space management by policy	•	•
Automated tape library support	•	•
<b>Operational Enhancements</b>	•	•
Simplified system configuration	•	•
Alternate nucleus	•	•
Fast warm start	•	•
Fast spool backup (SPXTAPE)	•	•
GVRP support <sup>6,8</sup>	-	•
IPv6 HiperSockets <sup>7,8</sup>	-	•
Improved VMRM enhancements for memory management for Linux guests <sup>7,9</sup>	-	•
Support for CMMA <sup>9</sup>	-	•
Dynamic system configuration	•	•
Dynamic system configuration including Coupling-over-InfiniBand (CIB) CHPID <sup>9</sup>	-	•
Enhanced timer management <sup>4</sup>	•	•
Virtual Machine accounting enhancements <sup>4</sup>	•	•
Systems management APIs <sup>5</sup>	•	•
HCD and HCM <sup>5</sup>	•	•
HMC integrated systems management <sup>9</sup>	-	•
VM Resource Manager <sup>4</sup>	•	•
Automated shutdown <sup>4</sup>	•	•
Installation from DVD	-	•
Guest ASCII console <sup>9</sup>	-	•
Password phrases (Passphrases) <sup>9</sup>	-	•
Dynamic LPAR addition/deletion	•	•
DirMaint performance improvement <sup>7</sup>	-	•
Coordinated DirMaint/RACF changes <sup>7</sup>	-	•
<b>Serviceability enhancements</b>	•	•
VMSES/E	•	•
<b>ShopzSeries</b>	•	•
<b>ESCON Architecture</b>	•	•
<b>FICON Architecture</b>	•	•
<b>Fibre Channel Protocol<sup>1</sup></b>	•	•
<b>Device Support</b>	•	•
FBA DASD	•	•
TotalStorage ESS	•	•
System Storage DS4000	-	•
System Storage DS6000	•	•
System Storage DS8000	•	•
System Storage FlashCopy V2 <sup>3</sup>	•	•
System Storage PPRC V2 <sup>3,20</sup>	•	•
Parallel Access Volumes (PAVs) as minidisks <sup>7,8</sup>	-	•
HyperPAV <sup>9</sup>	-	•
SVC Storage Engine 2145	-	•

VM Function	z/VM V4 <sup>22</sup>	z/VM V5
RAMAC Array Sub System	•	•
3390 DASD	•	•
3990 Model 6 MPLF Support	•	•
9340 DASD Subsystem	•	-
3494 Tape Library Subsystem	•	•
3495 Tape Library Dataserver	•	•
3590 Tape Drive	•	•
3592 Tape Controller (J70)/Drive (J1A) <sup>4,5</sup>	•	•
9348 Tape	•	-
3995 Optical Library Dataserver	•	-
<b>Minidisk Cache</b>	•	•
<b>Networking</b>	•	•
HiperSockets <sup>3</sup>	•	•
HiperSockets using IPv6 Protocol <sup>7,8</sup>	-	•
QEBSM and HPMA <sup>7,21</sup>	-	•
<b>OSA-2 <sup>24</sup></b>	•	•
<b>OSA-Express</b>	•	•
1000BASE-T Ethernet	•	•
Gigabit Ethernet (GbE)	•	•
Token-Ring <sup>3</sup>	•	•
<b>OSA-Express2</b>	•	•
1000BASE-T Ethernet	•	•
Gigabit Ethernet	•	•
10 GbE	•	•
<b>OSA-Express3 <sup>7,24</sup></b>	-	•
10 GbE	-	•
<b>System Management Products</b>	•	•
HMF	•	•
VMPAF <sup>22</sup>	•	•
PRF Feature <sup>22</sup>	•	-
RTM Feature <sup>22</sup>	•	-
Performance Toolkit for VM <sup>5</sup>	•	-
DirMaint 1.5 <sup>24</sup>	•	-
DirMaint Feature	•	•
RACF for VM 1.10 <sup>22</sup>	•	-
RACF Feature <sup>4,10</sup>	•	•
RACF Security Server FL530 Feature <sup>9</sup>	-	•
IBM Tivoli zSecure Manager for RACF z/VM	-	•
<b>Commnications</b>	•	•
RSCS FL530 feature <sup>9</sup>	-	•
RSCS V3.2.2 <sup>10,23</sup>	•	•
ACF/VTAM V4.2	•	•
TCP/IP for z/VM <sup>2</sup>	•	•
VM Passthrough Facility (PVM)	•	•
<b>Additional Features</b>	•	•
OSA/SF	•	•
Shell & Utilities <sup>1</sup>	•	•
CMS Utilities <sup>2</sup>	•	•

### Legend

- 1 Integrated in z/VM
  - 2 Integrated in z/VM V4 and later
  - 3 Supported on z/VM V4.2 and later
  - 4 Supported on z/VM V4.3 and later
  - 5 Supported on z/VM V4.4 and later
  - 6 Supported on z/VM V5.1 and later
  - 7 Supported on z/VM V5.2 and later
  - 8 Requires PTF for VM63952 for z/VM V5.2
  - 9 Supported on z/VM V5.3 and later
  - 10 Not supported on z/VM V5.3
  - 20 Guest use only
  - 21 Adapter-interruption performance assist is available only on z10 EC, z9 EC, z9 BC, z990, and z890 servers; QEBSM and HPMA are available only on z10 EC, z9 EC and z9 BC
  - 22 Withdrawn from Marketing
  - 23 Planned to be withdrawn from Marketing effective May 26, 2008
  - 24 Available only on the z10 EC
- Supported  
- Not applicable





## To learn more

Visit the Systems z World Wide Web site at [ibm.com/system/z/](http://ibm.com/system/z/) or call IBM DIRECT at 1 800 IBM-CALL in the U.S. and Canada.

Australia	132 426
Austria	0660.5109
Belgium	02-225.33.33
Brazil	0800-111426
China	(20) 8755 3828
Denmark	4520 8222
France	0800-03-03-03
Germany	01803-313233
Hong Kong	(20) 2825 6222
Hungary	165-4422
India	(80) 526 9050
Indonesia	(21) 252 1222
Ireland	1-850-205-205
Israel	03-6978111
Italy	167-017001
Japan	0120 300 426
Korea	(02) 781 7800
Malaysia	(03) 717 7890
Mexico	91-800-00316
Netherlands	020-513.5151
New Zealand	0800-801-800
Philippines	(02) 819 2426
Poland	(022) 878-6777
Singapore	1800 320 1975
South Africa	0800-130130
Spain	900-100400
Sweden	020-220222
Switzerland	0800 55 12 25
Taiwan	0800 016 888
Thailand	(02) 273 4444
Vietnam Hanoi	(04) 843 6675
Vietnam HCM	(08) 829 8342
United Kingdom	0990-390390

© Copyright IBM Corporation 2008

IBM Corporation  
New Orchard Rd  
Armonk, NY 10504  
U.S.A

Produced in the United States of America  
02-08

All Rights Reserved

References in this publication to IBM products or services do not imply that IBM intends to make them available in every country in which IBM operates. Consult your local IBM business contact for information on the products, features, and services available in your area.

IBM, IBM logo, AIX, APPN, DB2, DFSMS/VM, DirMaint, DRDA, DS4000, DS6000, DS8000, ESCON, FICON, FlashCopy, HiperSockets, HyperSwap, i5/OS, Multiprise, OS/400, Parallel Sysplex, QMF, RACF, RAMAC, RMF, S/370, S/390, System Storage, System z, System z9, Tivoli, TotalStorage, VM/ESA, VTAM, WebSphere, z9, z/Architecture, z/OS, z/VM, and z/VSE are trademarks or registered trademarks of the International Business Machine Corporation in the United States, other countries, or both.

Linux is a registered trademark of Linus Torvalds in the United States, other countries or both.

Java and all Java-based trademarks and logos are trademarks or registered trademarks of Sun Microsystems, Inc. in the United States or other countries.

UNIX is a registered trademark of The Open Group in the United States and other countries.

Microsoft, Windows and Windows NT are registered trademarks of Microsoft Corporation in the United States, other countries, or both.

InfiniBand is a registered trademark of the InfiniBand Trade Association.

ITIL is a registered trademark, and a registered community trademark of the Office of Government Commerce, and is registered in the U.S. Patent and Trademark Office

IT Infrastructure Library is a registered trademark of the Central Computer and Telecommunications Agency which is now part of the Office of Government Commerce.

Prices subject to change without notice. Contact your IBM representative or Business Partner for the most current pricing in your geography.

Other trademarks and registered trademarks are the properties of their respective companies.

References in this publication to IBM products or services do not imply that IBM intends to make them available in every country in which IBM operates. Consult your local IBM business contact for information on the products, features, and services available in your area.

IBM hardware products are manufactured from new parts, or new and used parts. Regardless, our warranty terms apply.

Photographs shown are of engineering prototypes. Changes may be incorporated in production models.

This equipment is subject to all applicable FCC rules and will comply with them upon delivery.

Information concerning non-IBM products was obtained from the suppliers of those products. Questions concerning those products should be directed to those suppliers.

All customer examples described are presented as illustrations of how those customers have used IBM products and the results they may have achieved. Actual environmental costs and performance characteristics may vary by custom.

All statements regarding IBM's future direction and intent are subject to change or withdrawal without notice, and represent goals and objectives only. Contact your local IBM office or IBM authorized reseller for the full text of a specific Statement of General Direction.